

ISCON

IBL catalogue





ISCON - LED Illumination for Machine Vision

ISCON products feature high light intensity, a wide array of available models and sizes as well as excellent build quality. Thanks to many years of experience in the machine vision industry, ISCON provides consultancy in terms of selecting the best illuminator model. ISCON also ensures user safety by adhering to stringent standards concerning electrical device safety. In order to guarantee high light intensity and long operation time, ISCON illuminators exclusively use the highest quality LEDs. A durable aluminium casing ensures increased resistance to mechanical damage and fire protection. Beside the highest quality and safety, ISCON also ensures express order processing. To maintain high quality of our illuminators, each product is subjected to many hours of stress tests before being delivered to the customer. ISCON products are fully manufactured within the European Union and bear the CE certificate.

ISCON illuminators are designed to operate in industrial machine vision systems. Using the correct illuminator in a machine vision system allows any physical property of an object to be inspected, including size, shape or inscription. Thanks to high light intensity, ISCON illuminators perform excellently in vision systems with a short illumination time of the inspected object. A wide array of models, light colour and additional accessories ensures versatility of ISCON illuminators, which allows them to perform perfectly in all types of vision systems. At the client's request, it is possible to design and manufacture custom illuminators, tailored to specific requirements of a machine vision system.

Selecting the correct ISCON illuminator for a vision system ensures:

- maximising the contrast between the inspected object and the background
- stable operating conditions of the machine vision system
- minimising the impact of the surrounding ambient light.



Scope of services:

- consultancy in terms of selecting the correct illuminator model
- custom builds at the customer's request
- free equipment rental for testing in actual conditions
- technical documentation for products
- warranty service and technical support.

- Maximum illuminated surface area despite small dimensions
- Durable, aluminium casing
- Wide range of dimensions
- Option of installing auxiliary filters



Product specifications

Supply voltage	24VDC
Operating temperature	0-60 °C
Protection rating	IP40
Cable	PUR cable up to 2m or 0.5m, M8, 3-pin
Cooling	Convection
Certificates	  
Casing	Anodised aluminium
Casing colour	Black

LED wavelength

W (white)	R (red)	G (green)	B (blue)	IR (infrared)
CRI=75	620-650nm	520-540nm	460-480nm	850-865nm

Overview drawing IBL-100-10-24x

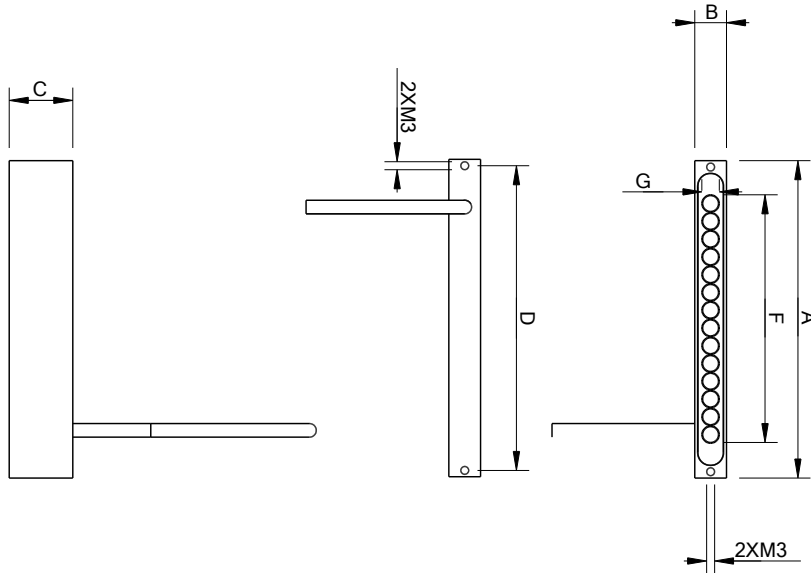

Tolerance of ± 0.5 mm applies to all of the dimensions given.

Overview drawing IBL-100-40-24x

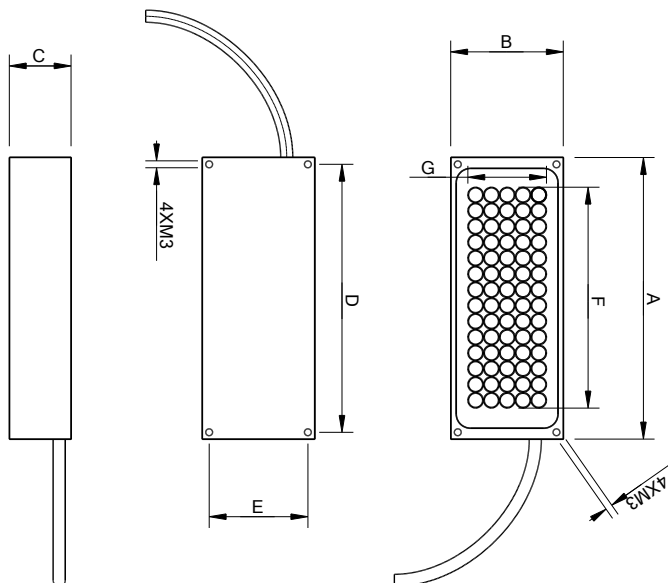



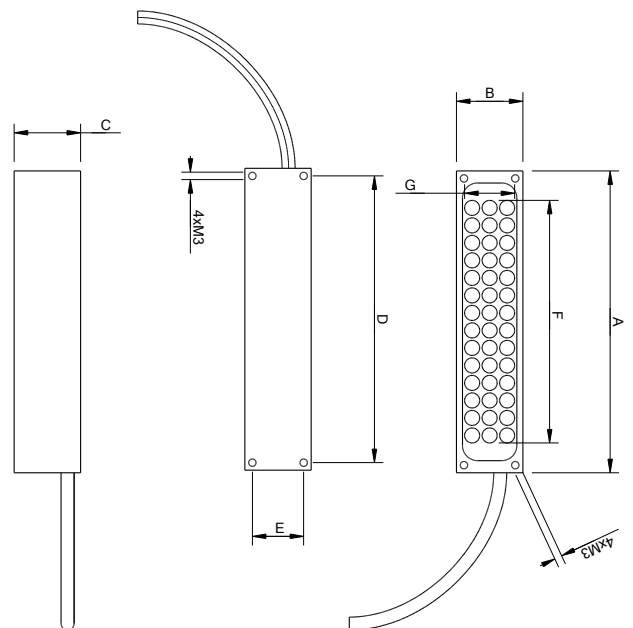









Overview drawing IBL-100-20-24x



Tolerance of ± 0.5 mm applies to all of the dimensions given.

Basic references

*	A [mm]	B [mm]	C [mm]	D [mm]	E [mm]	F [mm]	G [mm]	Colour	Power** [W]
IBL-70-10-24RWBG	60	10	20	56	-	39	6		1
IBL-70-10-24IR	60	10	20	56	-	39	6	IR	1
IBL-100-10-24RWBG	100	10	20	96	-	78	6		1
IBL-100-10-24IR	100	10	20	96	-	78	6	IR	1
IBL-180-10-24RWBG	180	10	20	176	-	158	6		1
IBL-180-10-24IR	180	10	20	176	-	158	6	IR	1
IBL-70-20-24RWBG	60	20	20	55	15	39	16		1
IBL-70-20-24IR	60	20	20	55	15	39	16	IR	1
IBL-100-20-24RWBG	100	22	20	95	17	79	16		4
IBL-100-20-24IR	100	22	20	95	17	79	16	IR	4
IBL-140-20-24RWBG	139	22	20	134	17	118	16		5
IBL-140-20-24IR	139	22	20	134	17	118	16	IR	5
IBL-260-20-24RWBG	258	22	20	253	17	237	16		9
IBL-260-20-24IR	258	22	20	253	17	237	16	IR	9
IBL-340-20-24RWBG	339	24	22	334	19	317	17		9
IBL-340-20-24IR	339	24	22	334	19	317	17	IR	9
IBL-420-20-24RWBG	418	24	22	413	19	397	16		12
IBL-420-20-24IR	418	24	22	413	19	397	16	IR	12
IBL-100-40-24RWBG	100	40	20	95	35	79	28		6
IBL-100-40-24IR	100	40	20	95	35	79	28	IR	6
IBL-180-40-24RWBG	180	40	20	175	35	159	28		12
IBL-180-40-24IR	180	40	20	175	35	159	28	IR	12
IBL-260-40-24RWBG	258	40	20	253	35	237	28		18
IBL-260-40-24IR	258	40	20	253	35	237	28	IR	18

* At the customer's request, illuminators can also be manufactured with custom dimensions.

In case of further questions please contact us at: iscon@iscon.pl.

** The specified power supply is required to power the device.

Tolerance of ± 0.5 mm applies to all of the dimensions given.

F, G - the illumination surface area

Reference coding

Model	Approximate length	Approximate width	Power supply	Colour code	Integrated strobe module	Connector
	[mm]	[mm]	VDC	RBGWIR	S	3 pin
IBL - xxx - xx - 24xxM8						
Colour code: W - white, R- red, B - blue, G - green, IR - infrared						

Example 1

IBL-100-20-24WM8

An illuminator with a length of A – 100mm, width of B – 22mm, white light colour, powered by 24VDC, with a cable up to 0.5m and an M8 connector (3-pin).

Example 2

IBL-140-20-24IR

An illuminator with a length of A – 139mm, width of B – 22mm, infrared light colour, powered by 24VDC, with a cable up to 2m and no connector – loose wires.

Example 3

IBL-100-40-24RSM8

An illuminator with a length of A – 100mm, width of B – 40mm, red light colour, powered by 24VDC, with an integrated strobe module, a cable up to 0.5m and an M8 connector (3-pin).

Example 4

IBL-180-10-24BS

An illuminator with a length of A – 180mm, width of B – 10mm, blue light colour, powered by 24VDC, with a strobe module, a cable up to 2m and no connector – loose wires.

Operation modes

The device allows for both continuous operation and operation in strobe mode. The next page contains connection diagrams for illuminators fitted with a strobe module or illuminators without a strobe module.

Connection Diagrams

An illuminator without a strobe module, e.g. **IBL-100-20-24R**

- Continuous operation



The illuminator can also operate in strobe mode, for example by using a relay or another external device to trigger the illuminator.

An illuminator with a strobe module, e.g. **IBL-100-20-24RS**

- Continuous operation



- Strobe mode operation



Strobe signal (black wire) between +5VDC and +24VDC. Minimum triggering current of 0.01A.

Connector Type

No connector (loose wires). Cable length up to 2m. For an illuminator without a strobe module.

For an illuminator without a strobe module, e.g. IBL-100-20-24R	
Brown	+24VDC
Blue	GND

No connector (loose wires). Cable length up to 2m. For an illuminator with a strobe module.

For an illuminator with a strobe module, e.g. IBL-100-20-24RS	
Brown	+24VDC
Black	Strobe signal
Blue	GND

With an M8 connector (3-pin, male). Cable length up to 0.5m. For an illuminator without a strobe module.

For an illuminator without a strobe module, e.g. IBL-100-20-24RM8	
Brown (BN)	+24VDC
Black (BK)	NA
Blue (BU)	GND

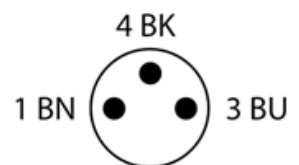

With an M8 connector (3-pin, male). Cable length up to 0.5m. For an illuminator with a strobe module.

For an illuminator with a strobe module, e.g. IBL-100-20-24RSM8	
Brown (BN)	+24VDC
Black (BK)	Strobe signal
Blue (BU)	GND



Installation and Application



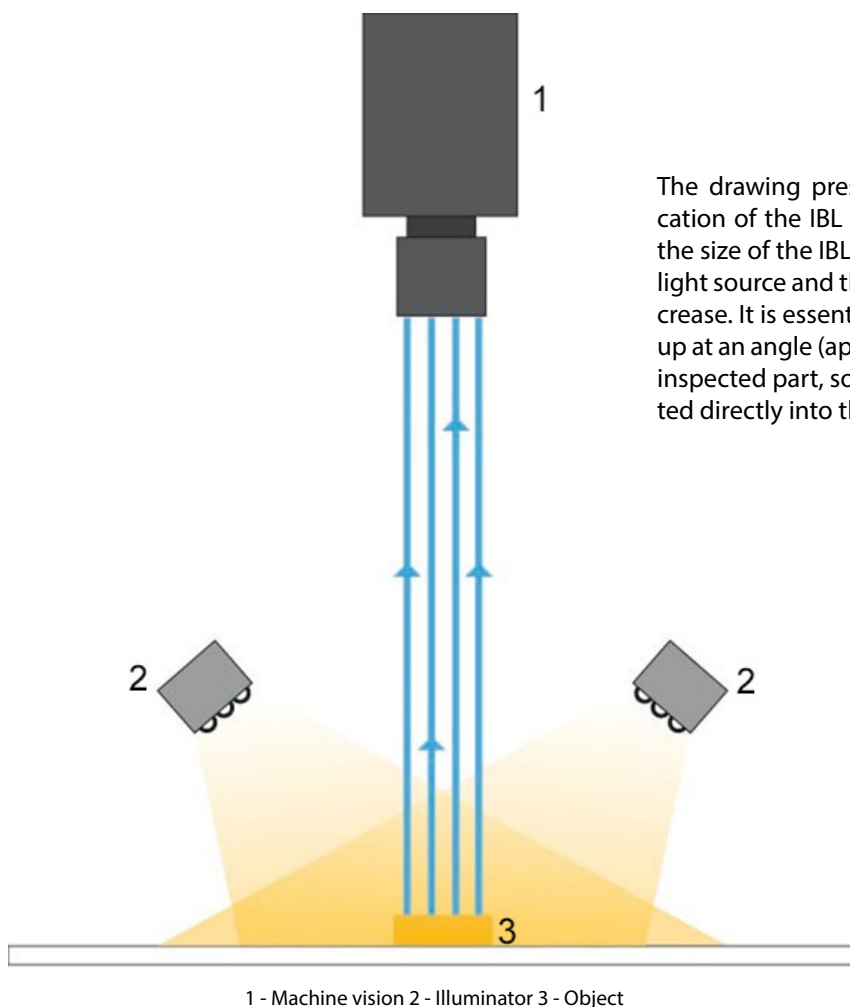









The illuminator is installed using 4 (2 for IBL-70-10-24x, IBL-100-10-24x and IBL-180-10-24x) M3x5 or M3x8 screws (not included with illuminators). The spacing between holes (D, E) is shown on the overview drawing. It is recommended to mount the illuminator on the machine's metal structure, so that its largest surface is aligned with the structure in order to dissipate the most heat. It is possible to mount a variety of filters or diffusers to the front part of the illuminator. Their designation is included in the 'Accessories' chart.



The drawing presents an exemplary application of the IBL illuminator. Depending on the size of the IBL, the distance between the light source and the part may increase or decrease. It is essential that illuminators are set up at an angle (approx. 30-55 degrees) to the inspected part, so that the light is not reflected directly into the camera lens.

It is also possible to polarise the illuminator's light by using additional filters. Polarising filters are also included in a separate 'Accessories' chart.

Warnings

	The surface of the illuminator may be hot.	Do not touch during operation. HOT.
	Do not look directly into the light source.	Caution, LED radiation.
	Keep away from fire and high temperatures (above 40°C).	Keep away from fire.
	Do not touch the device with wet hands.	Risk of electric shock or short circuit.
	Do not wet clean the device or use a pressure washer.	Risk of electric shock or short circuit.
	Connecting incorrectly may cause damage to the device.	Connect according to the information on the device's casing.
	The device is designed for operation in a dry room environment.	Do not touch during operation. HOT.
	Do not alter, cut or connect additional cables.	Exclusively use the original cable.
	Incorrect usage may lead to device damage.	Installation and application exclusively in accordance with technical documentation.
		Connect the device only with the power source cut off.
	Do not dismantle the device or remove original factory-made components.	Disassembly and technical modifications are prohibited.
		Protect from fall damage, strong shocks or impact to the device casing.

WARRANTY TERMS AND CONDITIONS

All ISCON products are subject to a 24-month warranty starting from the purchase date.

The warranty is honoured under the following conditions:

- Presenting the purchase invoice as well as the device's serial number or sending the device to the ISCON company address.
- The device must not have been disassembled, modified or otherwise customised to the user's needs. Incorrect installation (drilling through the casing or installing using different screws and holes than the ones anticipated by the manufacturer) voids the warranty.
- The device is powered with a direct current voltage 24-30V. Providing a higher or lower voltage or an alternate current may damage the illuminator and is not covered by the warranty.
- The device is designed for operation inside a dry room environment. Using it outside of a closed room may lead to exposure to moisture followed by damage and is not covered by the warranty.
- The device should not be cleaned using: water, pressure washers, hot steam, mechanical components and chemical agents.
- The room in which the illuminator operates must not be air tight without any air exchange or ventilation.
- The ambient temperature must be within 5-40°C.



Contact

ISCON

RAKOSZYCKA 2i
55-300 ŚRODA ŚLĄSKA
POLAND

iscon@iscon.pl
+48 609 336 674

www.iscon.pl

